

Applications: Internal Illumination for Large and Deep Sign Cabinets, Indoor and Outdoor

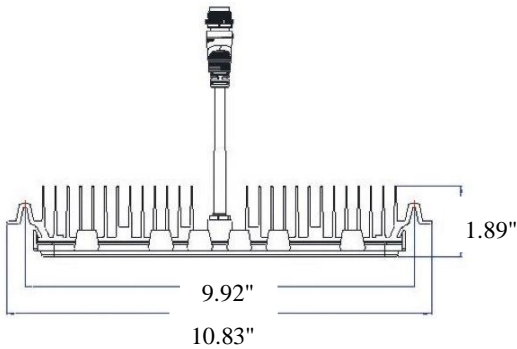
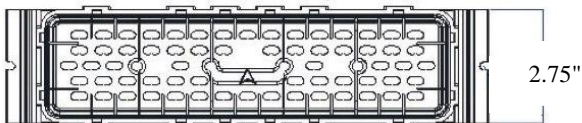
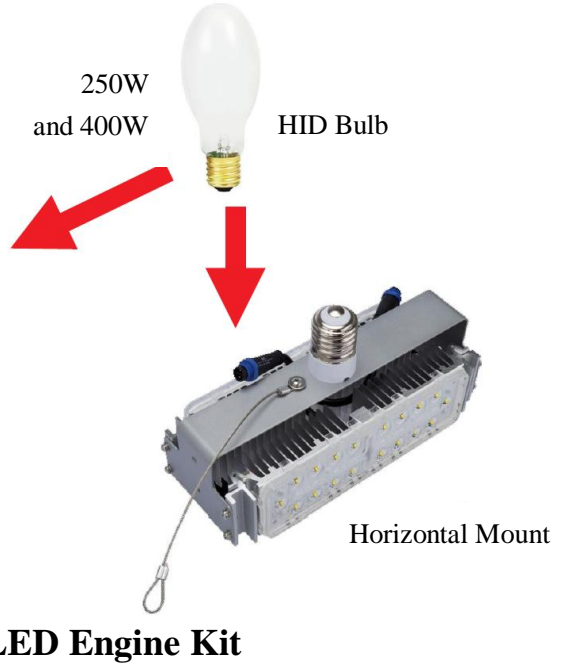

Model	Current	Watt	Color	Flux	IP	CRI	LEDs	Weight	Warranty
ZL-Engine-60W-50K	1050mA	60W	5000K	6600	IP 68	80	Lumileds	2 lbs	5 Yrs
ZL-Engine-60W-50K-Shallow				Lumen			(Phillip)		
HLG-120H-1050C	120-277VAC input, Constant Current Power Supply, 120W, 1050mA, One Power Supply for up to two ZL-Engine-60W-50K, 7 year warranty								
HLG-185H-1050C	120-277VAC input, Constant Current Power Supply, 185W, 1050mA, One Power Supply for up to three ZL-Engine-60W-50K, 7 year warranty								
ZL- C2A-S1M	Connectors to one ZL-Engine-60W-50K								
ZL- C2A-S2M	Connectors to two ZL-Engine-60W-50K								
ZL- C2A-S3M	Connectors to three ZL-Engine-60W-50K								
ZL-Engine-Bracket-E39	Bracket for double sided LED engines with removable E39 base and safety string								
ZL-C2A-Extension	Water proof power extension cord, 3FT								
ZL-Engine-Kit-Shallow	Kit includes ZL-Egnine-Braket-E39, 2 pcs of ZL-Engine-60W-50K-Shallow, 1 pc HLG-120H-1050C, 1 pc ZL-C2A-S2M								
ZL-Engine-Kit	Kit includes ZL-Egnine-Braket-E39, 2 pcs of ZL-Engine-60W-50K, 1 pc HLG-120H-1050C, 1 pc ZL-C2A-S2M								

Installation Guide

Retrofit:

- 1 PC ZL-Eninge-Kit Replaces 1 PC existing 400W HID Bulb
- 1 PC ZL-Engine-Kit-Shallow Replaces 1 PC existing 250W HID Bulb

New Construction:

	24"-30" Depth	30"-36" Depth	36"-40" Depth	40" and Up Depth
	Face-To-Face Distance	Face-To-Face Distance	Face-To-Face Distance	Face-To-Face Distance
ZL-Engine-60-50K-Shallow	24"-30" Spacing	30"-36" Spacing	36"-48" Spacing	
ZL-Engine-60-50K				48" Spacing